

THIS DOCUMENT IS SUBJECT TO CHANGE WITHOUT NOTICE. IT IS CONFIDENTIAL AND A PROPERTY OF Amphenol LTW. DISCLOSURE TO THIRD PARTY HAS TO BE AUTHORIZED BY Amphenol LTW.

REV.	ECN NO.	DATE	SIGN	DESCRIPTION
A	Initial Release	2012/10/22	Ruru	LD20-12RMFS-SS8001 To LD20-12PMFS-SN8001
B	LE31650235	2016/05/04	Vicky	Update Note

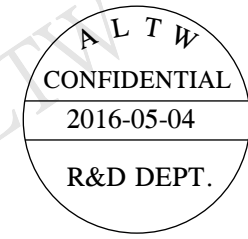

Assembly Instruction

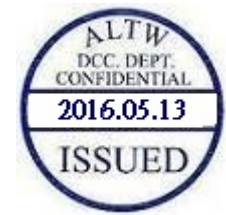
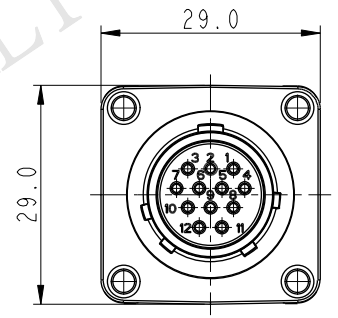
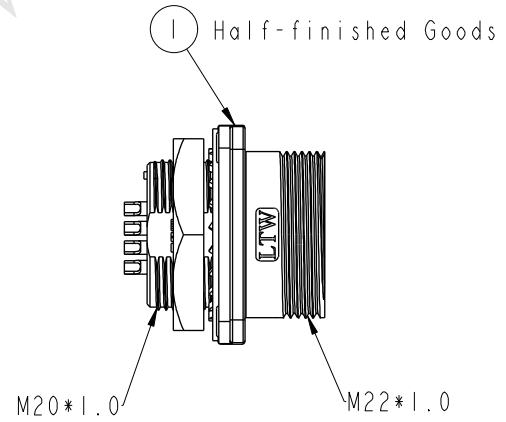
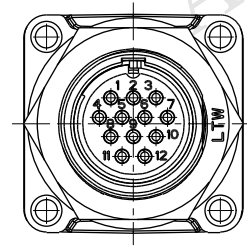
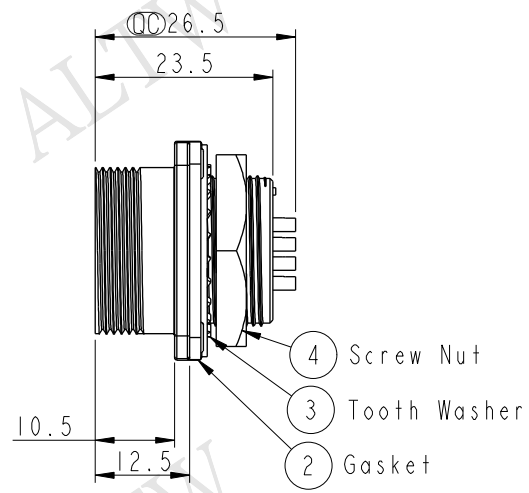
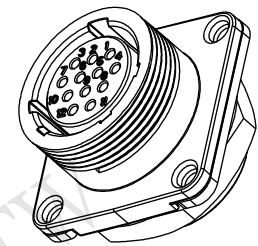
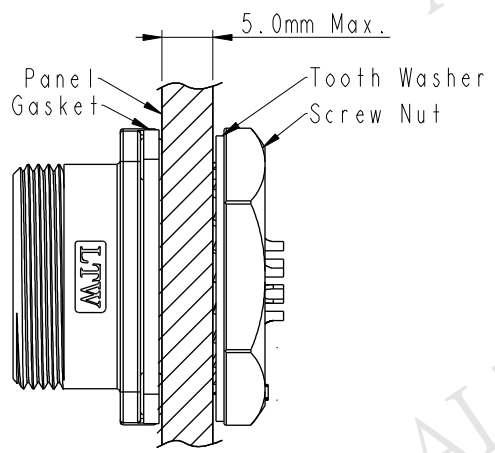

- Note:
- * \varnothing Important Dimension.
 - * Waterproof Rate: IP68
IP68: 1M depth of water in 24 Hrs.
(防水等級: IP68)
IP68: 水深一米測試 24 小時
 - * Shell: Zinc Alloy#3, Ni Plated, Silver.
 - * Insulation: Nylon, Black
 - * Female Pin: Copper Alloy, Silver Plated
 - * Gasket: Silicone, Gray
 - * Recommended Panel Thickness 5.0mm(Max).

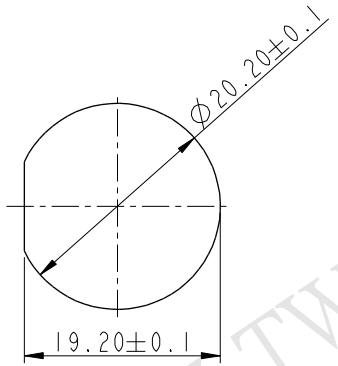

Recommend Panel Cut-Out

UNIT: mm		
TOLERANCE	.X ±0.25	
.XX ±0.1		
.XXX ±0.05		
ANGLES	±1°	

TITLE PANEL NUT 12PIN M CONN F PIN			
SCALE 1:1	SIZE A4	SHEET 1 OF 1	
REV. B	WC-REV. A.2	\varnothing : Inspection item	

Amphenol LTW
安費諾亮泰企業股份有限公司

ITEM NO. LD20-12PMFS-SN8001	DRAWN BY Vicky	DATE 2016-05-04
DWG NO. LD20-12PMFS-SN8001	CHECKED BY Rita	DATE 2016-05-04
CUSTOMER ALTW	APPROVED BY Lisa	DATE 2016-05-04