

THIS DOCUMENT IS SUBJECT TO CHANGE WITHOUT NOTICE. IT IS CONFIDENTIAL AND A PROPERTY OF AMPHENOL LTW. DISCLOSURE TO THIRD PARTY HAS TO BE AUTHORIZED BY AMPHENOL LTW.

REV.	ECN NO.	DATE	SIGN	DESCRIPTION
A		2019-11-06	Allen Pan	Rev.01 To Rev.A
B	C201347	2020/09/03	Eric	$\triangle B$ x1
C	C201758	2020/12/02	Allen	$\triangle C$ X2.

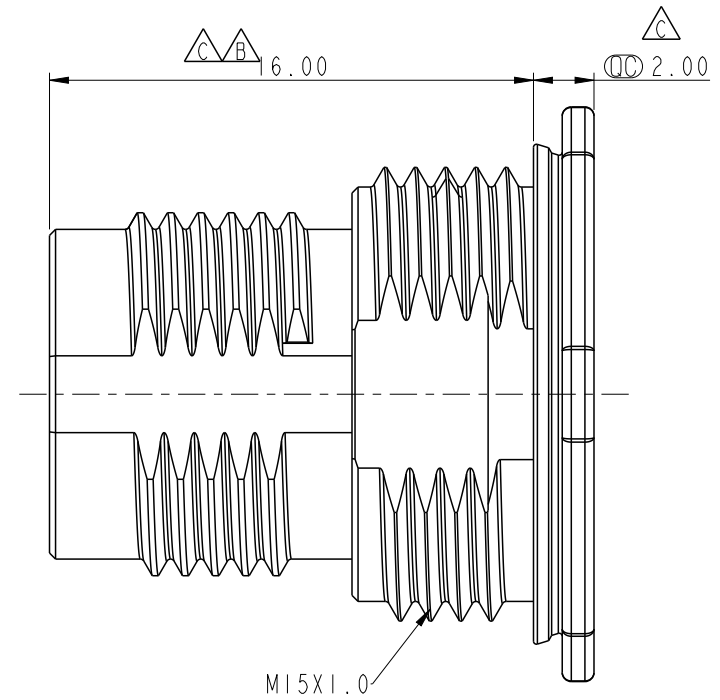

Note:
 * Material: Metal
 * Salt Spray: 96hr
 * For Panel Thickness Max. 4mm

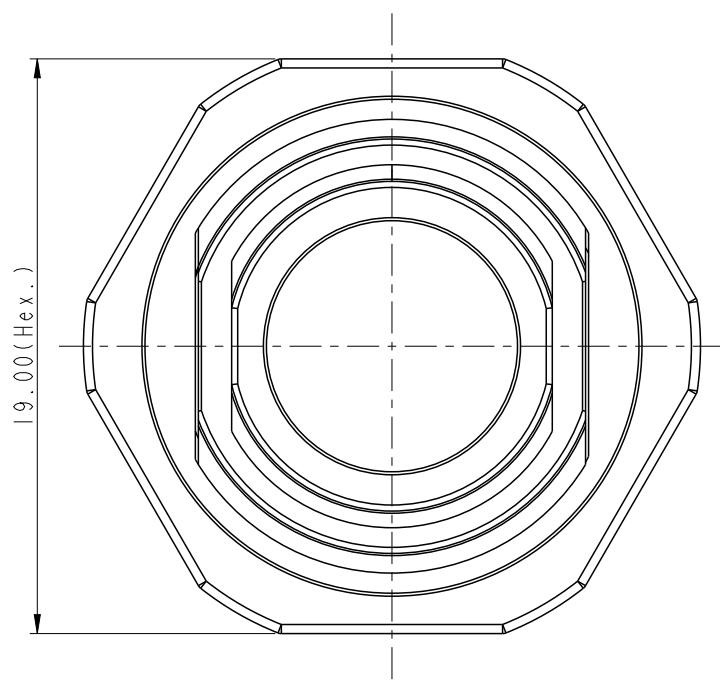
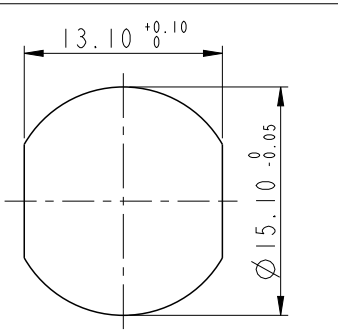

Recommended
Panel Cut-out (Scale 2:1)

UNIT: mm		
TOLERANCE		
.X	±0.25	
.XX	±0.1	
.XXX	±0.05	
ANGLES	±1°	

TITLE M12 Front Fastened Male Panel Nut		
SCALE 3:1	SIZE A4	SHEET 1 OF 1
REV. C	WC-REV. A.1	\odot : Inspection item

Amphenol LTW
 安費諾亮泰企業股份有限公司

ITEM NO. APTM-BMZMA012-001	DRAWN BY Allen Pan	DATE 2019-11-06
DWG NO. APTM-BMZMA012-001	CHECKED BY Fred Lee	DATE 2019-11-06
CUSTOMER ALTW	APPROVED BY Fred Lee	DATE 2019-11-06