

REV.	ECN NO.	DATE	SIGN	DESCRIPTION
B	C180591	2018-12-19	Sam Ho	Update Description
C	C201258	2020-08-31	Sam Ho	XI

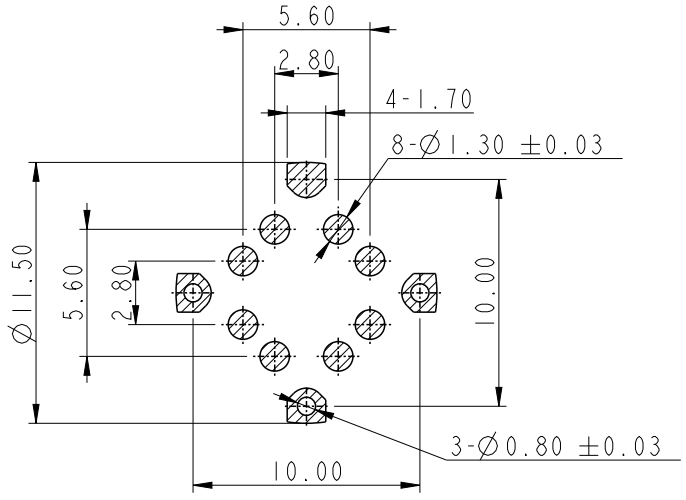

Recommended PCB Layout
General tolerance: ±0.05mm

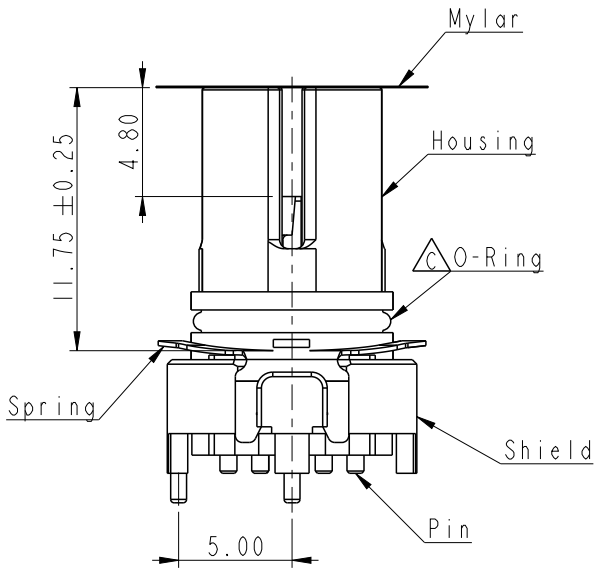
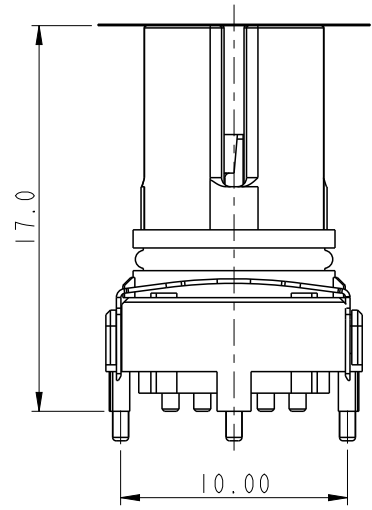
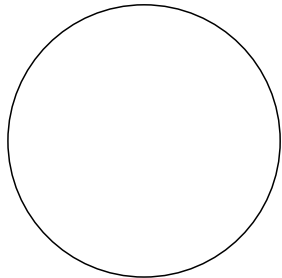
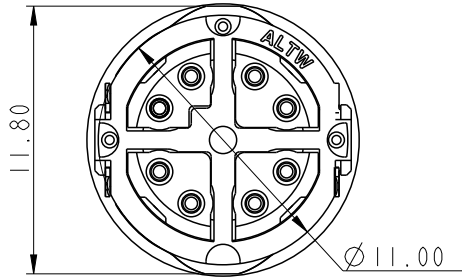

- Note:
- * Connector: Thermoplastic, Black
 - * Female Pin: Copper Alloy, Gold Plated
 - * Shield & Spring: Metal
 - * Withstand voltage test 2.2KVdc between shield and pin, 500Vac between adjacent pin
 - * Coplanarity of all contacts: 0.10mm maximum.

UNIT: mm		
TOLERANCE	.X	±0.25
	.XX	±0.1
	.XXX	±0.05
ANGLES		±1°

TITLE M12 X Code Panel Ended SMT Type		
SCALE 3:1	SIZE A4	SHEET 1 OF 3
REV. C	WC-REV.	Inspection item

Amphenol LTW
安費諾亮泰企業股份有限公司

ITEM NO. MSXS-08PFFT-EE0001	DRAWN BY Sam Ho	DATE 2018-12-19
DWG NO. MSXS-08PFFT-EE0001	CHECKED BY Fred Lee	DATE 2018-12-19
CUSTOMER ALTW	APPROVED BY Fred Lee	DATE 2018-12-19

THIS DOCUMENT IS SUBJECT TO CHANGE WITHOUT NOTICE. IT IS CONFIDENTIAL AND A PROPERTY OF AMPHENOL LTW. DISCLOSURE TO THIRD PARTY HAS TO BE AUTHORIZED BY AMPHENOL LTW.

THIS DOCUMENT IS SUBJECT TO CHANGE WITHOUT NOTICE. IT IS CONFIDENTIAL AND A PROPERTY OF Amphenol LTW. DISCLOSURE TO THIRD PARTY HAS TO BE AUTHORIZED BY Amphenol LTW.

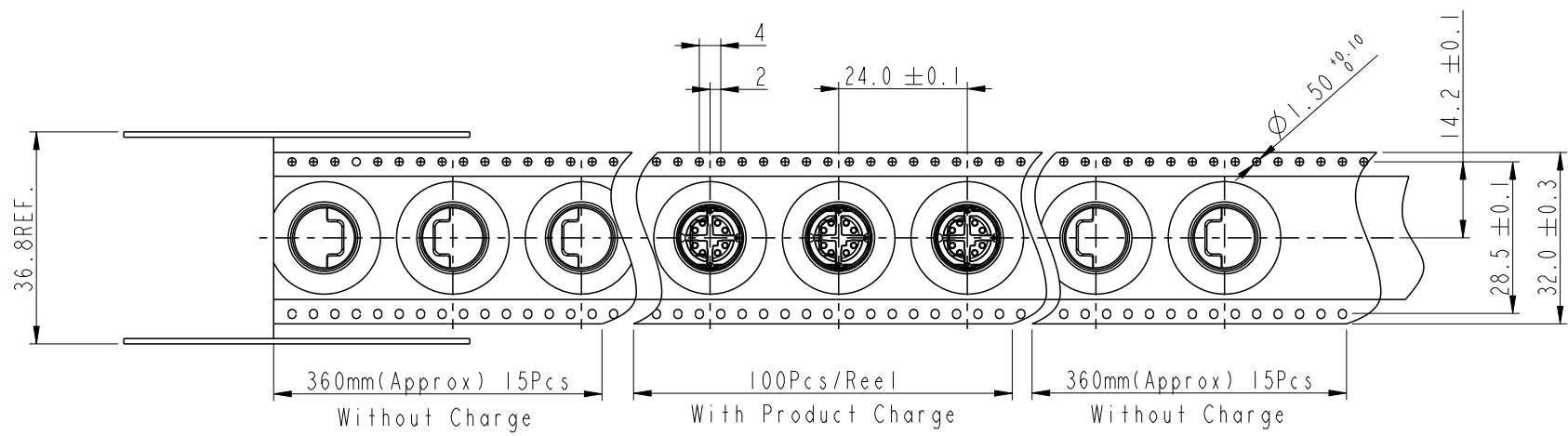

Top of Reel →

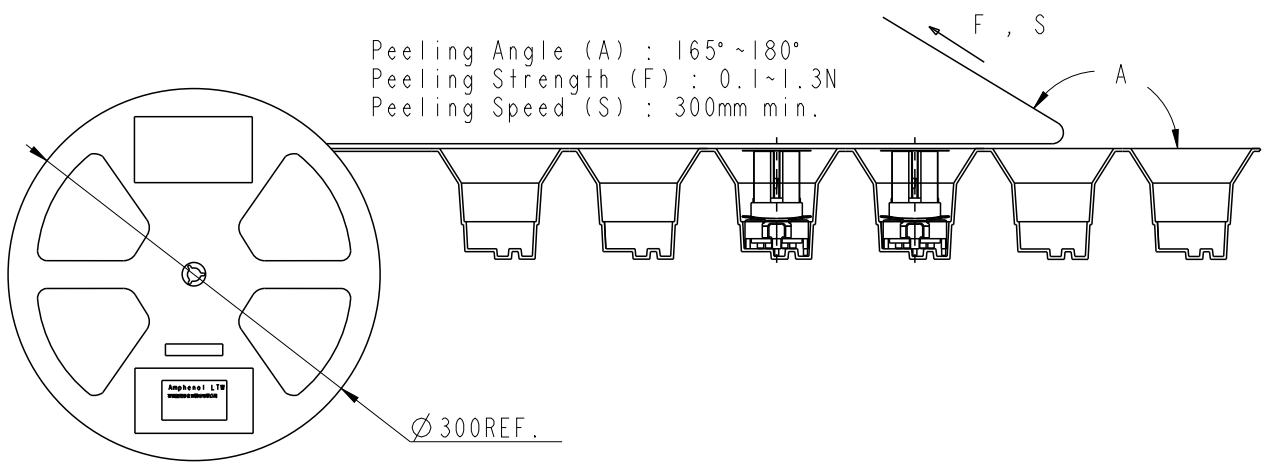

UNIT: mm		
TOLERANCE	.X ±0.25	.XX ±0.1
	.XXX ±0.05	ANGLES ±1°

TITLE M12 X Code Panel Ended SMT Type		
SCALE Free	SIZE A4	SHEET 2 OF 3
REV. C	WC-REV.	: Inspection item

Amphenol LTW
安費諾亮泰企業股份有限公司

ITEM NO MSXS-08PFFT-EE0001	DRAWN BY Sam Ho	DATE 2018-12-19
DWG NO MSXS-08PFFT-EE0001	CHECKED BY Fred Lee	DATE 2018-12-19
CUSTOMER ALTW	APPROVED BY Fred Lee	DATE 2018-12-19

THIS DOCUMENT IS SUBJECT TO CHANGE WITHOUT NOTICE. IT IS CONFIDENTIAL AND A PROPERTY OF Amphenol LTW. DISCLOSURE TO THIRD PARTY HAS TO BE AUTHORIZED BY Amphenol LTW.

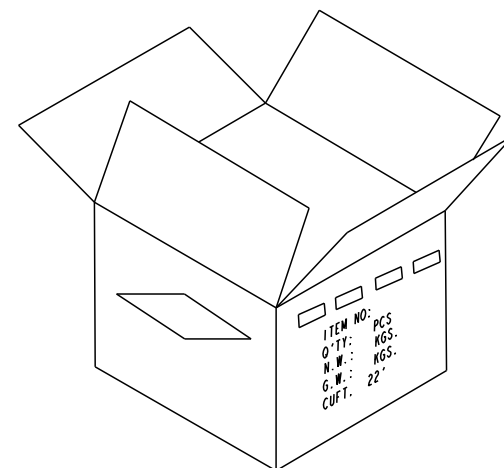
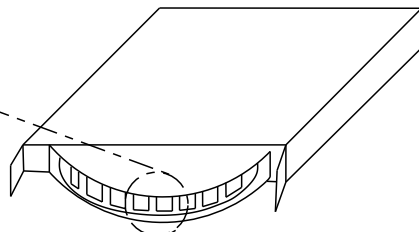
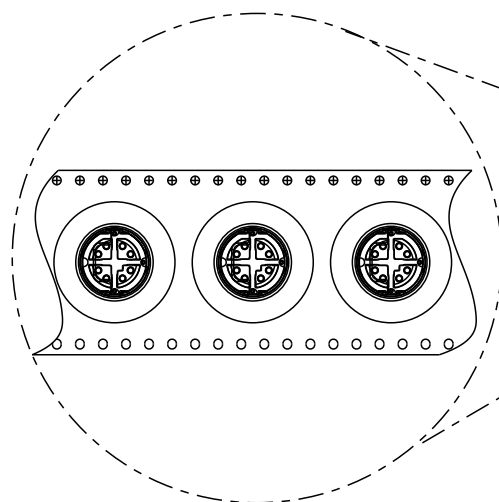
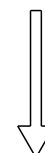
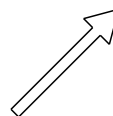
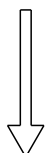
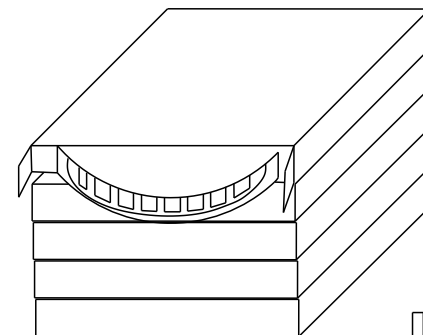
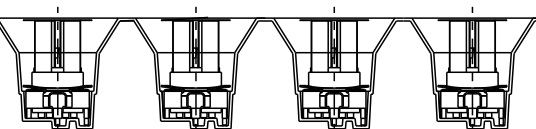
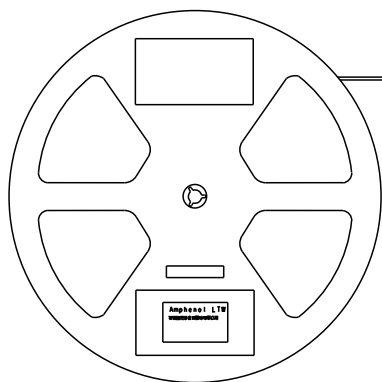

Notes:
 *Tape&Reel(Box) Quantity : 100pcs/Reel(Box).
 *Carton Quantity : 500pcs/Carton.

UNIT:mm		TITLE			ITEM NO	DRAWN BY	DATE
		M12 X Code Panel Ended SMT Type			MSXS-08PFFT-EE0001	Sam Ho	2018-12-19
		SCALE	SIZE	SHEET	DWG NO	CHECKED BY	DATE
TOLERANCE	±0.25	A4	3 OF 3	MSXS-08PFFT-EE0001	Fred Lee	2018-12-19	
.X	±0.1	WC-REV.		CUSTOMER	APPROVED BY	DATE	
.XX	±0.05	C	☉: Inspection item	ALTW	Fred Lee	2018-12-19	
.XXX	±1°						
ANGLES							

Amphenol LTW
 安費諾亮泰企業股份有限公司